

INSTALLATION INSTRUCTIONS

DESCRIPTION: Rear Overfender Kit

PART NUMBER: B8K-F15E0-S0

MODEL: '18~ Wolverine X2



⚠ WARNING

Please read and understand these instructions completely before installation to avoid possible injury, or damage to the accessory or vehicle.

NOTICE:

This installation requires a torque wrench and should be performed by an authorized Yamaha dealer or other qualified technician.

WARRANTY INFORMATION:

In the United States, see your Yamaha dealer for a copy of the warranty statement.

DEALER OR INSTALLER:

These instructions contain important information for future reference and *must* be given to the customer.

PARTS LIST:

| No. | Part Number | Description | Qty |
|-----|--------------|-----------------------|-----|
| -- | B8K-F15E0-S0 | Rear Overfender Kit | -- |
| ① | B8K-F1560-00 | Right Rear | 1 |
| ② | B8K-F1559-00 | Left Rear | 1 |
| ③ | 90110-06090 | M6x16 Button Head | 12 |
| ④ | 95602-06200 | M6 Locking Flange Nut | 12 |
| ⑤ | 90201-06802 | M6 Washer | 12 |

* Part supplied with kit only and not available separately.

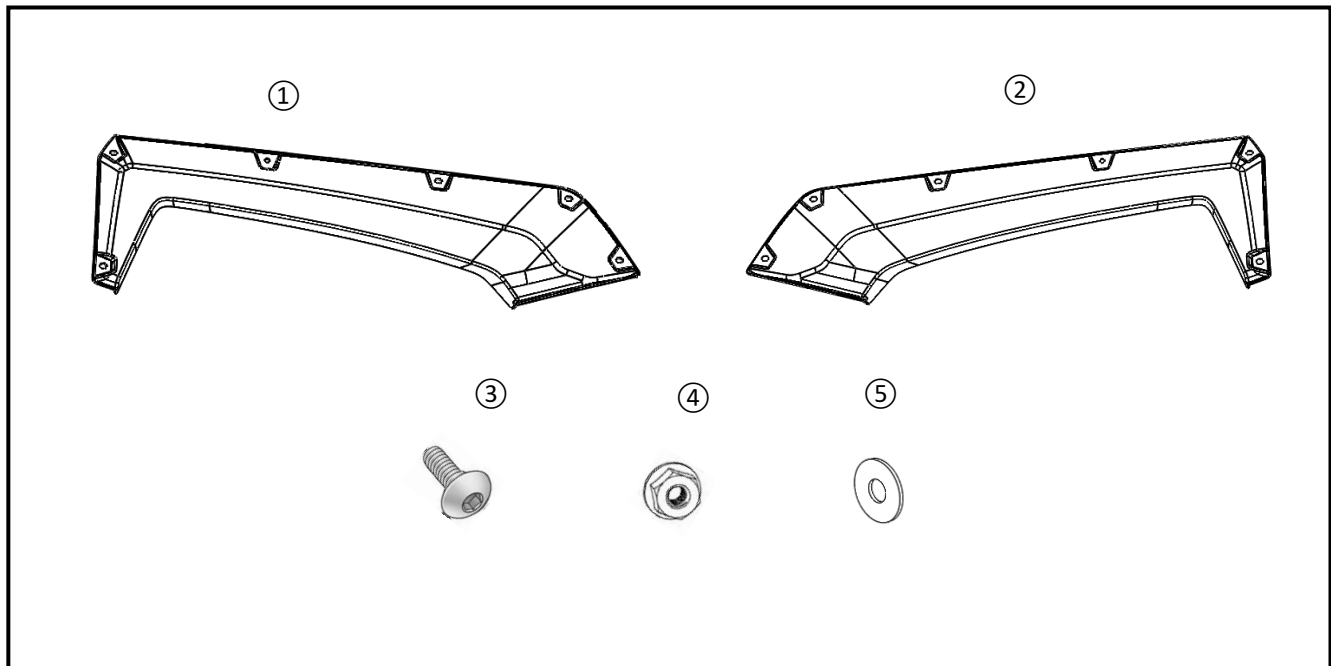

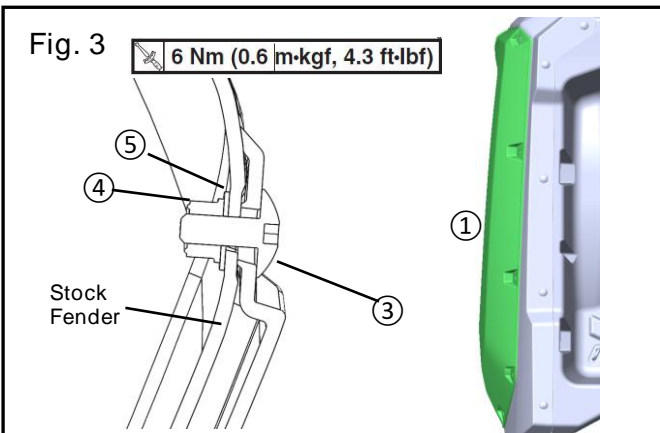
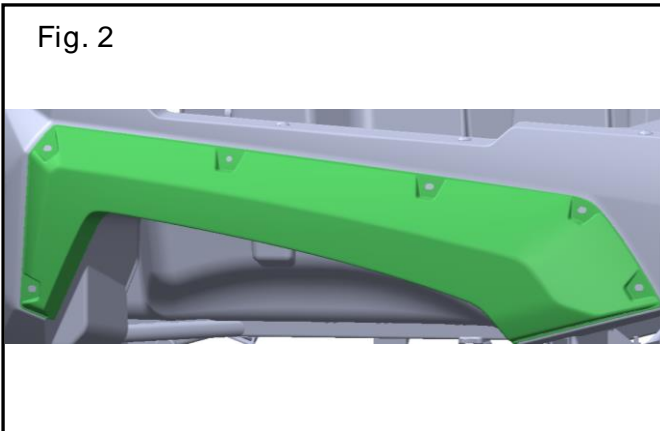
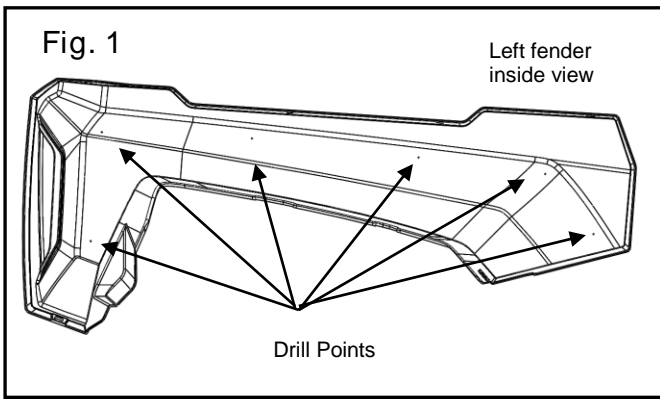

PREPARATION:

- Place the vehicle on a secure and level surface.
- Set the parking brake.
- Clean the mount surfaces before starting installation.

INSTALLATION:

1. Remove the rear left fender from the vehicle by removing the top five button head cap screws and two M6 Hex Bolts on the underside of the fender.
2. The inside of the fender has 6 drill point locations (small dimples in the plastic). Using an 8mm (5/16") drill bit, drill each of the six locations inside the fender, remove any burrs or debris from drilling. (see Fig. 1).
3. Repeat step 1 & 2 on the right fender.
4. On the right rear, position the ① Overfender so that the mounting holes align with the mounting holes in the fender. Install a ③ Button Head bolt into each hole. On the inside of the fender, install a ⑤ Washer and thread a ④ Flanged Lock nut onto each bolt. (See Fig. 2).
5. Attach the left ② Rear Overfender to the vehicle using step 4.
6. Adjust the Overfenders position and then torque bolts to 6 Nm (0.6 m·kgf, 4.3 ft·lbf). (See Fig. 3).

MAINTENANCE:

Periodically, check torque and tightness on all hardware. If loose hardware is found, re-torque or re-tighten.

CARE AND CLEANING:

Wash using clean soft cloth and mild soap and water. Rinse and dry. Using Yamacoat™ spray (ACC-YAMAC-OA-TC), available from your Yamaha dealer, will help keep the overfenders and other plastics easy to clean and looking new.

CUSTOMER SERVICE:

For further information see your Yamaha dealer.

ESTIMATED TIME TO INSTALL: 1.0 HR